

Simple Set Max (SSM) - 2-Way, 2-1/2" - 12" — GA(S) Series Actuators

IOM Manual



Table of Contents

Simple Set Max - Installation, Operation and Maintenance Manual

Technical Specifications	2
Safety Instructions	3
Product Description/Function	3
Installation/Mounting Positions	4
Kit Components	5
Assembly	6-8
ANSI 125 Flow Rate Charts	9-13
ANSI 250 Flow Rate Charts	14-16

**FOR MORE INFORMATION ON THIS PRODUCT
AND OTHER BRAY PRODUCTS
PLEASE VISIT OUR WEBSITE - www.braycommercialdivision.com**

Technical Specifications - Valve		
Service	Hot Water, Chilled Water, 50-50 Glycol Solutions	
Size Range	2-Way	2-1/2" through 12" (DN 65 to 300)
Cold Working Pressure	2-1/2" through 12" - 232 PSI @ 100°F, ANSI 125 2-1/2" through 12" - 500 PSI @ 100°F, ANSI 250	
Media Temperature Range	2.5" to 5"	32°F to 248°F (0°C to 120°C)
	6" to 12"	32°F to 230°F (0°C to 110°C)
Min. Operational ΔP	Refer to Flow Rate Charts on Pages 9 thru 16	
Max. Operational ΔP	116 PSID (800kPa)	
Max. Close-Off Pressure	116 PSI (800kPa)	
Valve Operation	Push down to close, Normally Open	
Shut-Off Leakage	<ANSI ClassIV (0.01%)	
Flow Rate Range	19.27 to 2641 GPM	
Stroke	2.5" & 3"	0.79" (20mm)
	4" & 5"	1.58" (40mm)
	6" & 8"	1.69" (43mm)
	10" & 12"	1.89" (48mm)
Rangeability	>100:1	
Flange Connections	ANSI 125 & ANSI 250	
Test Ports	1/4" NPT	
Materials	Body	2-1/2" thru 6" - Cast Iron 8" thru 12" - Ductile Iron
	Flow Regulation Unit	Stainless Steel
	Diaphragm	Reinforced EPDM (Ethylene Propylene Diene Monomer)
	Spring	Stainless Steel
	O-Rings	EPDM
Warranty	5 Years limited from time of shipment.	
Weights	See Dimensions - Pages 17 & 18	

Disclaimer - The pipe system shall be properly ventilated to avoid risk of air pockets. Glycolic mixtures up to 50% are applicable (both ethylene and propylene). Bray can accept no responsibility if another actuator is used instead of the Bray actuator recommendation: Water treatment to VDI 2035.



Safety Instructions - Definition of Terms

Read, Follow and Save these instructions



WARNING

Indicates a potentially hazardous situation which, if not avoided, could result in death or serious injury.



CAUTION

Indicates a potentially hazardous situation which, if not avoided, may result in minor or moderate injury.

NOTICE

Used without the safety alert symbol indicates a potential situation which, if not avoided, may result in an undesirable result or state, including property damage.

Qualified Personnel

A qualified person in terms of this document is one who is familiar with the installation, commissioning and operation of the device and who has appropriate qualifications, such as:

- Is trained in the operation and maintenance of electric equipment and systems in accordance with established safety practices.
- Is trained or authorized to energize, de-energize, ground, tag and lock electrical circuits and equipment in accordance with established safety practices.

- Is trained in the proper use and care of personal protective equipment (PPE) in accordance with established safety practices.

- Is trained in first aid.

- In cases where the device is installed in a potentially explosive (hazardous) location – is trained in the operation, commissioning, operation and maintenance of equipment in hazardous locations.

Product Description

Bray's Simple Set Max combines an externally adjustable dynamic balancing valve with a full authority modulating control valve.

Available in both ANSI 125 and ANSI 250 configurations.

Function

The air temperature of the Air Handling Unit is controlled by a sensor in the outlet. When the control system calls for higher or lower temperature on the air outlet, the PICV opens or closes to increase or decrease the flow through the coil. The power output from the coil follows a parabolic curve where often an EQ% valve/actuator characteristic is chosen to have a direct relation between the input control signal and power output.



Figure 1 Installation

Bray's Simple Set Max can be mounted in either the supply or the return line. Installation of strainers and isolation ball valves are recommended. The temperature in and about the actuator should not be below 14°F (-10°C). We recommend mounting downstream to the coil to minimize temperature extremes.

Note:
System flow **MUST** match flow arrow on valve.

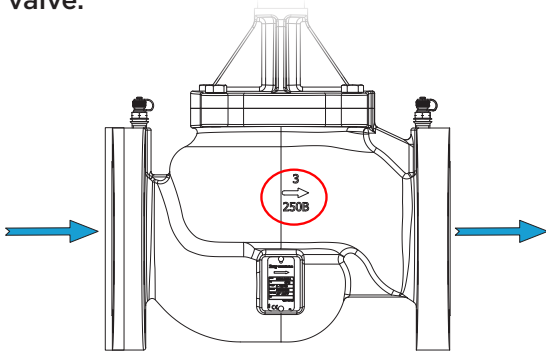

Figure 1

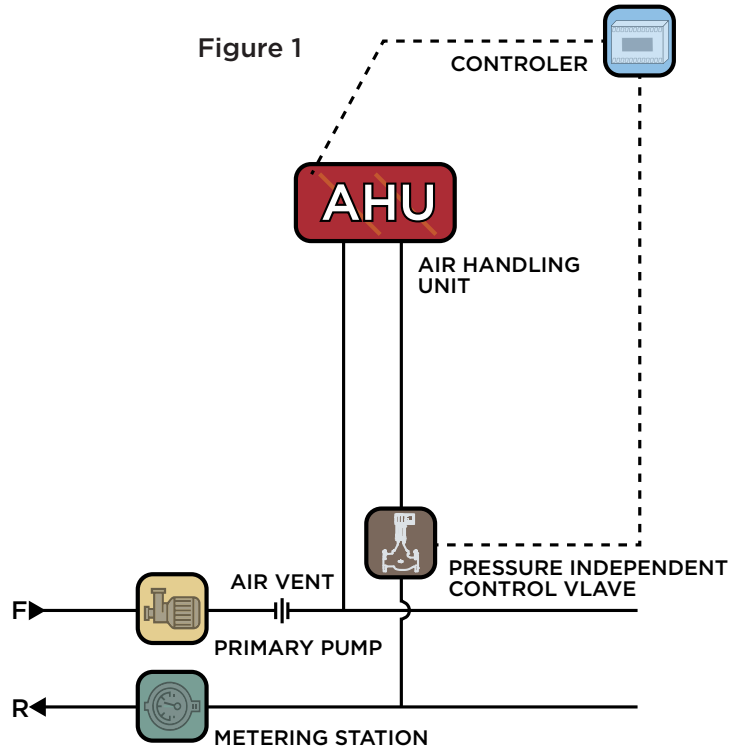
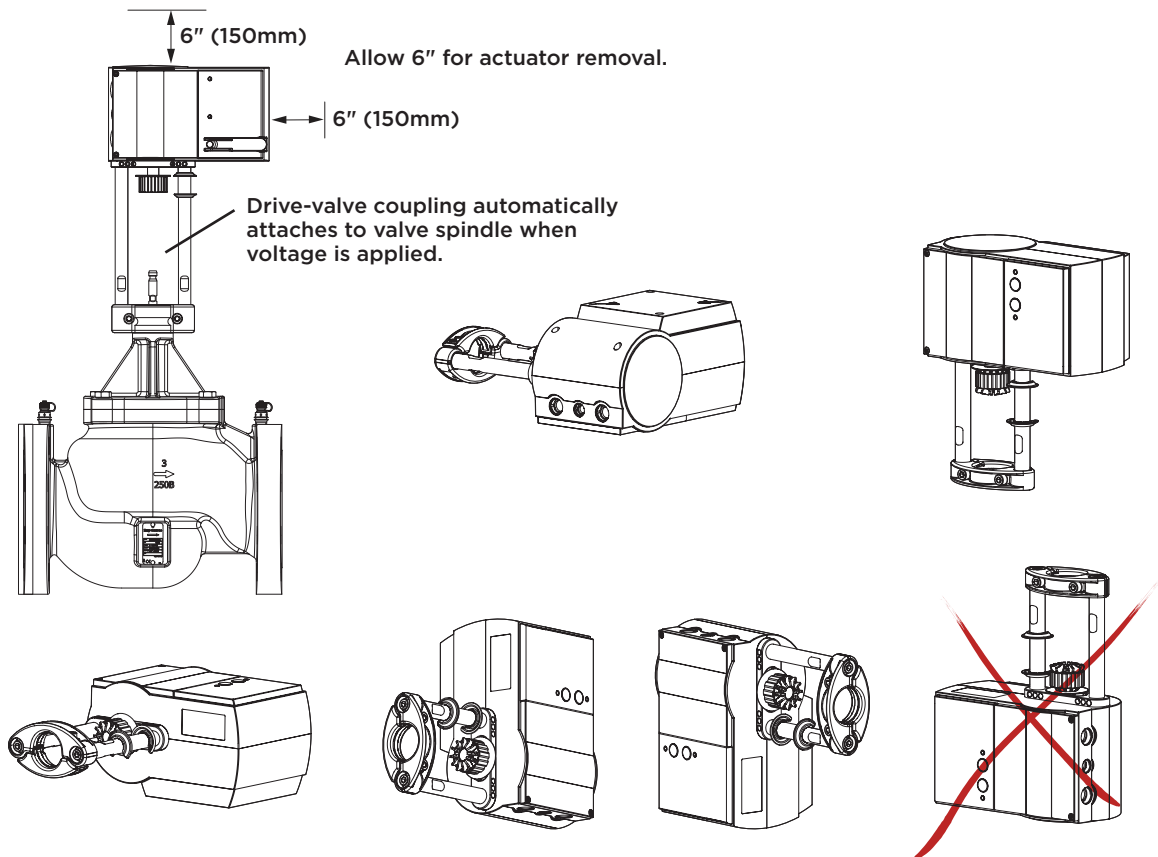

Figure 2 Mounting Positions

Actuator mounting positions for GA Series Actuators

Figure 2





Precautions:

- Wear safety glasses and wear safety glasses and appropriate safety equipment before performing any of the listed tasks.
- Assure all components are present before assembly.

Kit Components

Figure 3A

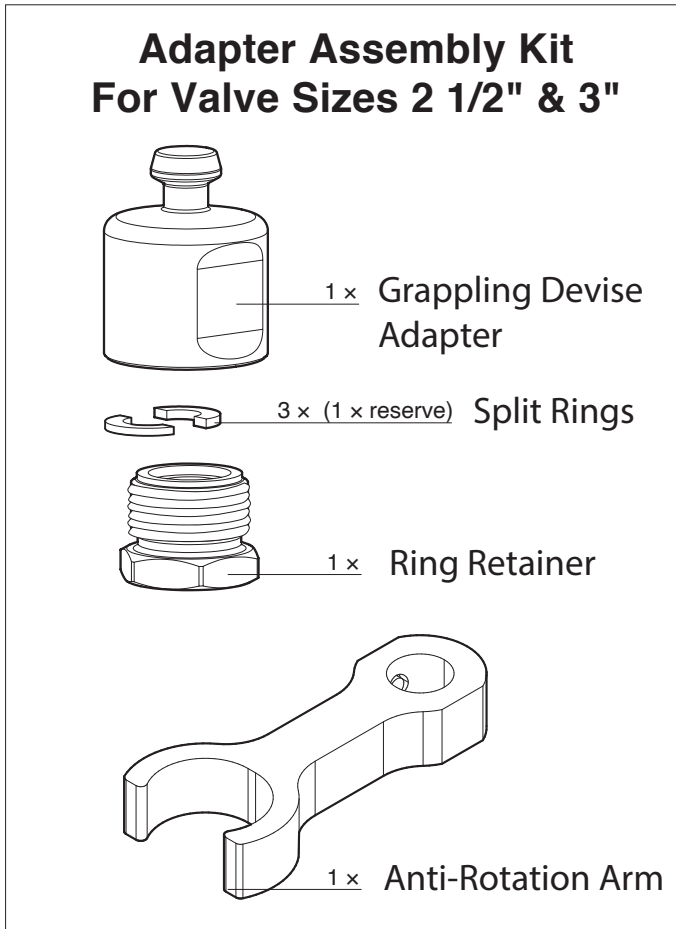
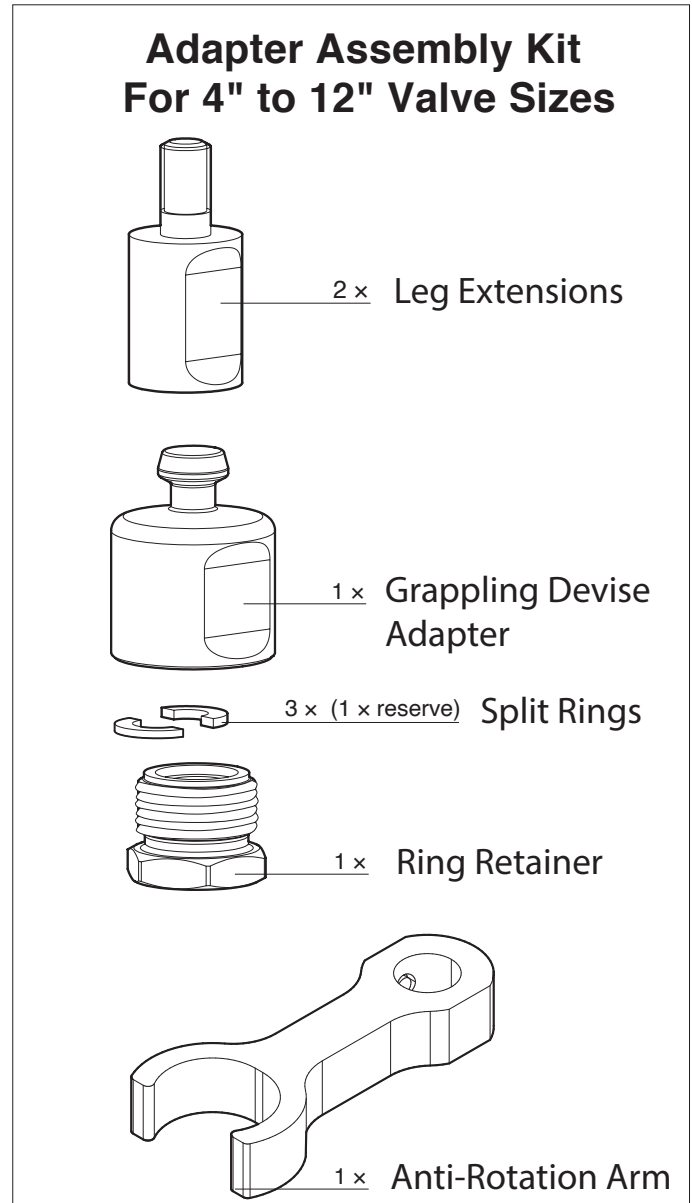
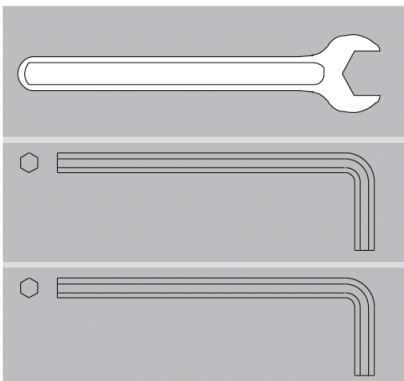

Figure 3B



Tools and Equipment Required



22 & 24 mm Wrench
(or Crescent Wrench)

6 mm Allen Wrench

2.5 mm Allen Wrench



PRE-ASSEMBLY NOTE:

- (2) Steel Shims will be placed on top of valve stem before any other components
- The Shims will reduce valve travel due to the force output of the actuator
- Steel Shims come included with this kit and assembly

Figure 4

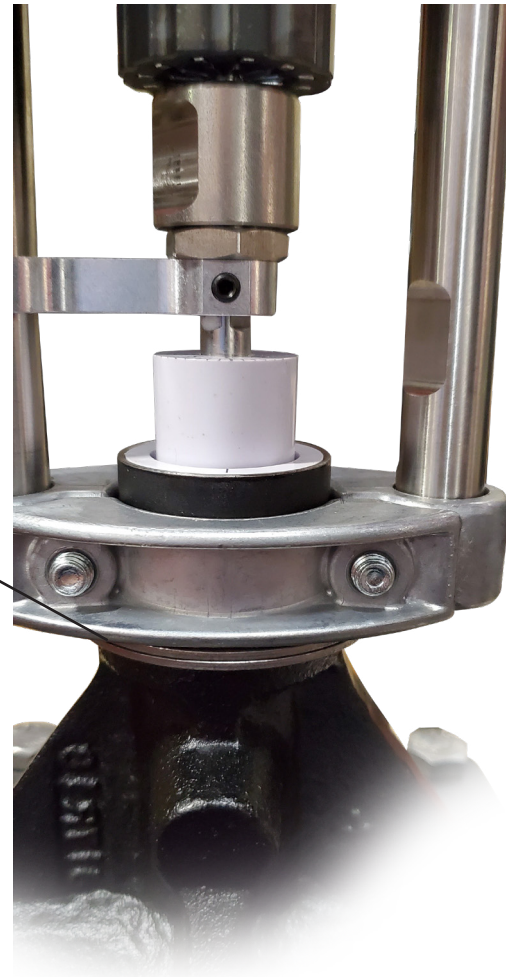

Final Assembly with Shims

ASSEMBLY:

- Inspect the actuator for any sign of physical damage.
- Using the actuator manual override assure actuator full shaft extension retraction. If spring return, assure that spring extension/retraction is functioning properly.
- Prior to assembly the actuator shaft should be fully retracted, except for spring extended models, and the grappling claw should be in the extended position.
- 2-½" & 3" Valves use Adaptor Kit 0510390052. 4" to 12" valves use Adaptor Kit 0510390053, this kit includes leg extensions.

Figure 5

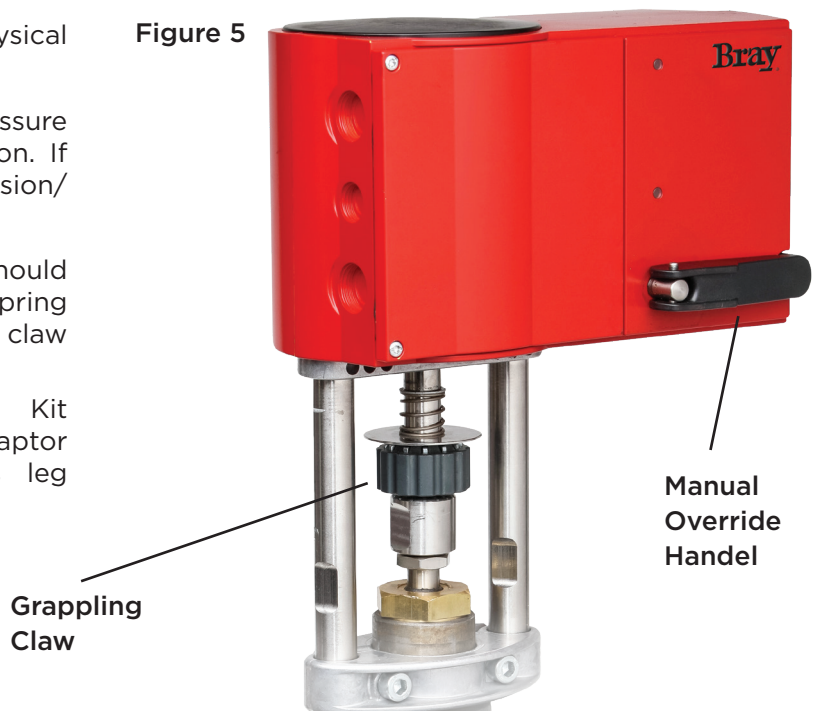



ASSEMBLY Continued:

- Remove the neck clamp mechanism by removing the two leg fasteners using 6mm Allen wrench. (Part #3)
- Assemble the two leg extensions (Part #2) to the actuator legs (4" to 12" valves only.)
- Reassemble the neck clamp to leg extensions by installing the two leg fasteners. (Part #3)
- Using the 6mm Allen wrench, remove the threaded neck clamp (Part #4) of the actuator by removing the two neck clamp fasteners. (Part #5)
- With the actuator oriented as shown, [Figure 8] actuator handle face on the same side as valve tag, assemble the actuator on to valve using the neck clamping mechanism. Assure that the neck clamp is seated properly into the valve neck groove.
- First --> have to assemble coupler part # 9 to part #8
- Take the anti-rotation arm (Part #6) open end and clasp the actuator legs (flat surface) and allow it to slide downwards.
- Assemble the grappling device adapter (Part #9) to the valve stem with two split rings (Part #7) and split ring retainer. [Figure 6] (Part #9)

Figure 6

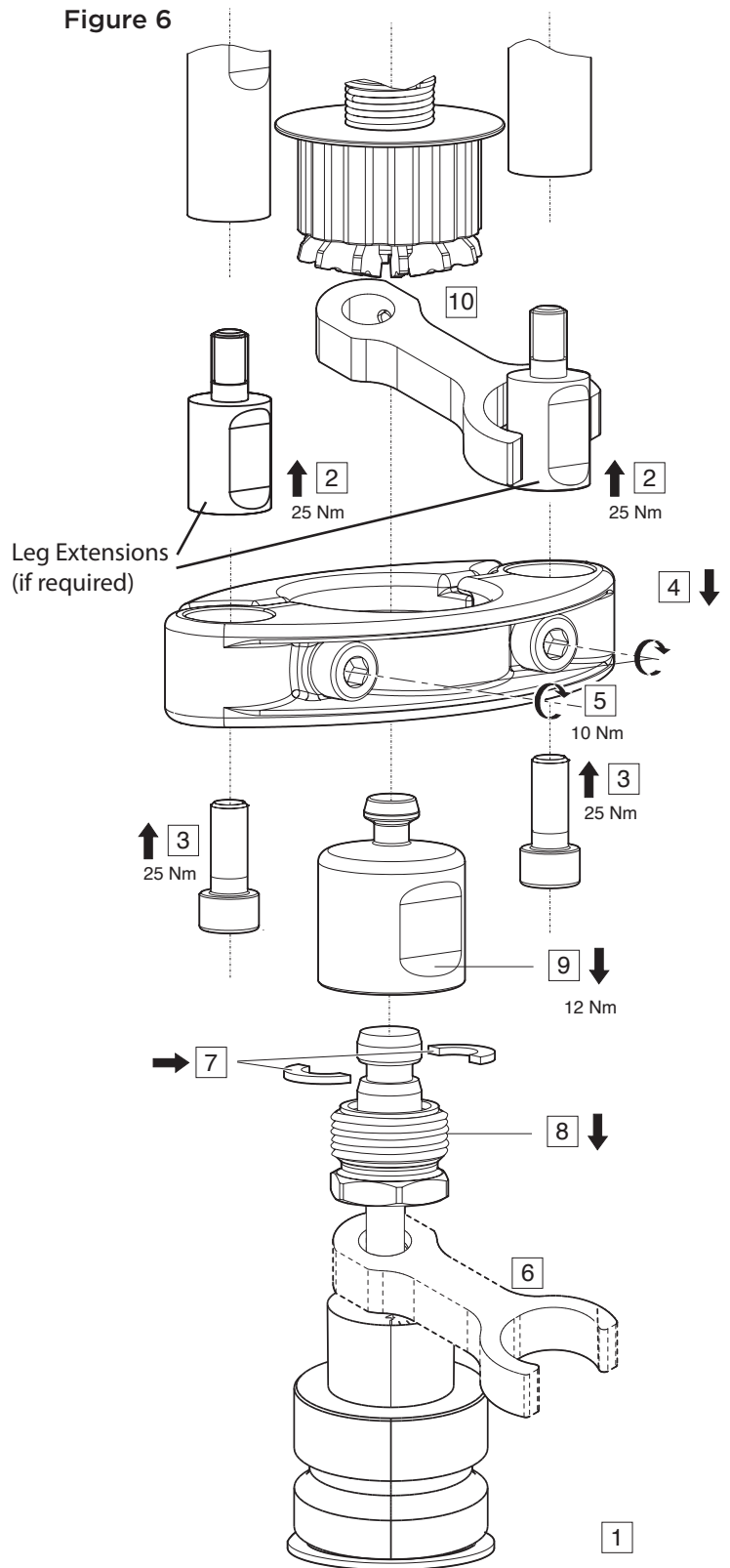

Note: The two split rings fit into the split ring groove and the split ring retainer screws into the grappling device adapter.



Note: For spring extended actuators the shaft may need to be retracted, using the manual override, to a position which allows for assembly.

- Using the actuator manual override extend the actuator shaft and capture the grappling device adapter with the grappling device. (Part #10)



Note: For spring extended actuators the grappling device adapter may be captured by the grappling device during actuator assembly.

- Assure that the grappling claw is fully retracted into the grappling device.



Figure 7

**ASSEMBLY Continued:
GPM Settings:**

- Inspect the actuator for any sign of physical damage.
- Refer to the Flow Rate Charts on page 6 or the flow rate calculator at

<https://braycommercialdivision.com/product/simple-set-max-pressure-independent-control-valve/>

for the dial setting that correlates to the specified GPM.

- Turn the valve's white dial located under stem [Figure 7] to desired setting.
- Using 2.5mm Allen Wrench tighten the anti-rotation arm set screw around valve stem.

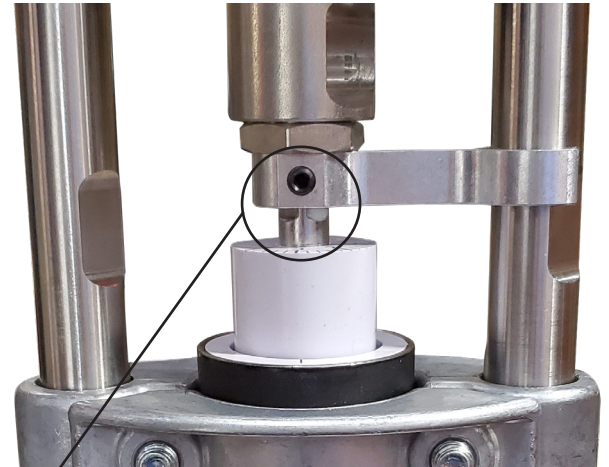

IMPORTANT!

1. Ensure the set screw is against the curved edge of the stem, not the flats. Failure to do so can lead to alterations of the gpm setting during operation.



2. If changing the flow rate on an already installed actuator, or to rotate the actuator to a different orientation, loosen the set screw. Failure to do so may result in damaging internal components of the valve.



IMPORTANT!

Pipe insulation shall not cover dial drain hole.

Figure 8

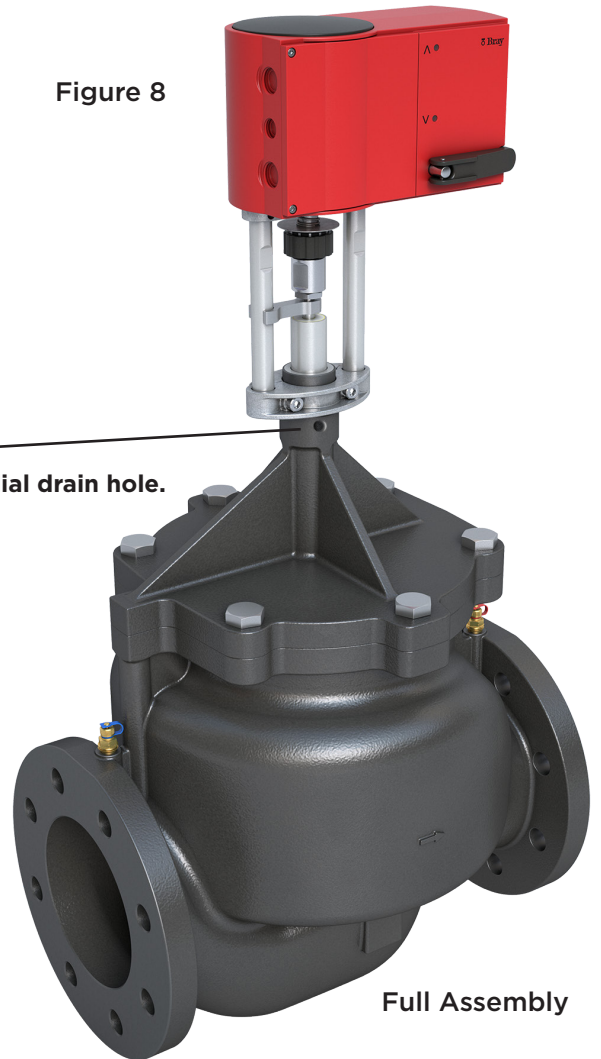

Full Assembly

Overview

For Wiring and Operating Instructions for the GA(S) Actuators refer to:

<https://braycommercialdivision.com/product/gas-series-globe-valve-actuators/>



Simple Set Max - ANSI 125 Flow Rate Charts

2-1/2"		2-1/2" Low Flow Rate Cartridge		
Model Number	Pre-Set	Min. Delta P	Flow m ³ /h	Flow GPM
SSM-250-A-L-19	0.6	2.18	4.4	19
SSM-250-A-L-24	0.8	2.18	5.6	24
SSM-250-A-L-29	1.0	2.18	6.6	29
SSM-250-A-L-34	1.2	2.31	7.7	34
SSM-250-A-L-38	1.4	2.41	8.6	38
SSM-250-A-L-42	1.6	2.49	9.6	42
SSM-250-A-L-46	1.8	2.55	10.5	46
SSM-250-A-L-51	2.0	2.61	11.5	51
SSM-250-A-L-55	2.2	2.66	12.5	55
SSM-250-A-L-60	2.4	2.7	13.5	60
SSM-250-A-L-65	2.6	2.76	14.7	65
SSM-250-A-L-70	2.8	2.82	15.8	70
SSM-250-A-L-75	3.0	2.9	17.1	75
SSM-250-A-L-81	3.2	3	18.5	81
SSM-250-A-L-88	3.4	3.11	19.9	88
SSM-250-A-L-95	3.6	3.26	21.5	95
SSM-250-A-L-102	3.8	3.42	23.2	102
SSM-250-A-L-110	4.0	3.59	25.0	110

2-1/2"		2-1/2" High Flow Rate Cartridge		
Model Number	Pre-Set	Min. Delta P	Flow m ³ /h	Flow GPM
SSM-250-A-H-26	0.6	4.35	6.0	26
SSM-250-A-H-33	0.8	4.35	7.6	33
SSM-250-A-H-40	1.0	4.35	9.1	40
SSM-250-A-H-46	1.2	4.51	10.5	46
SSM-250-A-H-53	1.4	4.6	11.9	53
SSM-250-A-H-59	1.6	4.64	13.3	59
SSM-250-A-H-65	1.8	4.65	14.7	65
SSM-250-A-H-71	2.0	4.64	16.0	71
SSM-250-A-H-77	2.2	4.64	17.5	77
SSM-250-A-H-84	2.4	4.67	19.0	84
SSM-250-A-H-91	2.6	4.74	20.6	91
SSM-250-A-H-98	2.8	4.87	22.3	98
SSM-250-A-H-106	3.0	5.09	24.1	106
SSM-250-A-H-114	3.2	5.4	26.0	114
SSM-250-A-H-123	3.4	5.81	28.0	123
SSM-250-A-H-133	3.6	6.36	30.2	133
SSM-250-A-H-143	3.8	7.06	32.5	143
SSM-250-A-H-154	4.0	8.01	35.0	154

3"		3" Low Flow Rate Cartridge		
Model Number	Pre-Set	Min. Delta P	Flow m ³ /h	Flow GPM
SSM-3-A-L-26	0.6	2.32	5.3	26
SSM-3-A-L-30	0.8	2.32	6.9	30
SSM-3-A-L-36	1.0	2.33	8.3	36
SSM-3-A-L-42	1.2	2.41	9.6	42
SSM-3-A-L-48	1.4	2.47	10.9	48
SSM-3-A-L-54	1.6	2.52	12.2	54
SSM-3-A-L-59	1.8	2.57	13.5	59
SSM-3-A-L-65	2.0	2.61	14.8	65
SSM-3-A-L-71	2.2	2.65	16.2	71
SSM-3-A-L-77	2.4	2.7	17.6	77
SSM-3-A-L-84	2.6	2.75	19.1	84
SSM-3-A-L-91	2.8	2.82	20.7	91
SSM-3-A-L-99	3.0	2.9	22.4	99
SSM-3-A-L-107	3.2	3	24.3	107
SSM-3-A-L-116	3.4	3.13	26.4	116
SSM-3-A-L-126	3.6	3.28	28.7	126
SSM-3-A-L-138	3.8	3.44	31.2	138
SSM-3-A-L-150	4.0	3.61	34.0	150

3"		3" High Flow Rate Cartridge		
Model Number	Pre-Set	Min. Delta P	Flow m ³ /h	Flow GPM
SSM-3-A-H-31	0.6	3.34	7.0	31
SSM-3-A-H-40	0.8	3.34	9.0	40
SSM-3-A-H-48	1.0	3.34	11.0	48
SSM-3-A-H-56	1.2	3.43	12.8	56
SSM-3-A-H-64	1.4	3.49	14.5	64
SSM-3-A-H-71	1.6	3.53	16.2	71
SSM-3-A-H-79	1.8	3.57	18.0	79
SSM-3-A-H-86	2.0	3.61	19.6	86
SSM-3-A-H-94	2.2	3.68	21.4	94
SSM-3-A-H-102	2.4	3.77	23.2	102
SSM-3-A-H-111	2.6	3.91	25.1	111
SSM-3-A-H-119	2.8	4.11	27.1	119
SSM-3-A-H-129	3.0	4.39	29.3	129
SSM-3-A-H-139	3.2	4.75	31.6	139
SSM-3-A-H-150	3.4	5.19	34.1	150
SSM-3-A-H-162	3.6	5.73	36.8	162
SSM-3-A-H-175	3.8	6.39	39.8	175
SSM-3-A-H-189	4.0	7.19	43.0	189

Note: Min. Delta P Available at Selected Flow Rate.
See Website for Specific Flow Rate Settings Calculator



Simple Set Max - ANSI 125 Flow Rate Charts

4"		4" Low Flow Rate Cartridge		
Model Number	Pre-Set	Min. Delta P	Flow m ³ /h	Flow GPM
SSM-4-A-L-53	0.6	2.75	12.1	53
SSM-4-A-L-67	0.8	2.83	15.3	67
SSM-4-A-L-80	1.0	2.9	18.1	80
SSM-4-A-L-91	1.2	2.96	20.8	91
SSM-4-A-L-102	1.4	3.02	23.2	102
SSM-4-A-L-112	1.6	3.08	25.5	112
SSM-4-A-L-122	1.8	3.13	27.8	122
SSM-4-A-L-132	2.0	3.19	30.0	132
SSM-4-A-L-143	2.2	3.25	32.4	143
SSM-4-A-L-154	2.4	3.32	34.9	154
SSM-4-A-L-166	2.6	3.4	37.6	166
SSM-4-A-L-179	2.8	3.5	40.6	179
SSM-4-A-L-194	3.0	3.63	44.0	194
SSM-4-A-L-210	3.2	3.78	47.7	210
SSM-4-A-L-229	3.4	3.98	51.9	229
SSM-4-A-L-249	3.6	4.25	56.7	249
SSM-4-A-L-273	3.8	4.6	62.0	273
SSM-4-A-L-299	4.0	5.08	68.0	299

4"		4" High Flow Rate Cartridge		
Model Number	Pre-Set	Min. Delta P	Flow m ³ /h	Flow GPM
SSM-4-A-H-65	0.6	4.14	14.8	65
SSM-4-A-H-83	0.8	4.24	18.9	83
SSM-4-A-H-99	1.0	4.35	22.6	99
SSM-4-A-H-114	1.2	4.48	26.0	114
SSM-4-A-H-128	1.4	4.61	29.1	128
SSM-4-A-H-141	1.6	4.75	32.1	141
SSM-4-A-H-154	1.8	4.91	35.1	154
SSM-4-A-H-168	2.0	5.08	38.1	168
SSM-4-A-H-181	2.2	5.27	41.2	181
SSM-4-A-H-196	2.4	5.5	44.5	196
SSM-4-A-H-212	2.6	5.78	48.2	212
SSM-4-A-H-230	2.8	6.11	52.2	230
SSM-4-A-H-250	3.0	6.52	56.7	250
SSM-4-A-H-272	3.2	7.05	61.9	272
SSM-4-A-H-298	3.4	7.7	67.7	298
SSM-4-A-H-327	3.6	8.51	74.2	327
SSM-4-A-H-360	3.8	9.56	81.7	360
SSM-4-A-H-396	4.0	10.87	90.0	396

5"		5" Low Flow Rate Cartridge		
Model Number	Pre-Set	Min. Delta P	Flow m ³ /h	Flow GPM
SSM-5-A-L-81	0.6	2.32	18.5	81
SSM-5-A-L-104	0.8	2.32	23.6	104
SSM-5-A-L-125	1.0	2.32	28.5	125
SSM-5-A-L-147	1.2	2.39	33.3	147
SSM-5-A-L-167	1.4	2.46	38.0	167
SSM-5-A-L-188	1.6	2.51	42.6	188
SSM-5-A-L-207	1.8	2.56	47.1	207
SSM-5-A-L-227	2.0	2.61	51.5	227
SSM-5-A-L-246	2.2	2.67	55.9	246
SSM-5-A-L-266	2.4	2.73	60.4	266
SSM-5-A-L-286	2.6	2.81	65.0	286
SSM-5-A-L-308	2.8	2.91	69.8	308
SSM-5-A-L-330	3.0	3.05	75.0	330
SSM-5-A-L-355	3.2	3.23	80.6	355
SSM-5-A-L-382	3.4	3.48	86.7	382
SSM-5-A-L-412	3.6	3.83	93.6	412
SSM-5-A-L-446	3.8	4.34	101.3	446
SSM-5-A-L-484	4.0	5.08	110.0	484

5"		5" High Flow Rate Cartridge		
Model Number	Pre-Set	Min. Delta P	Flow m ³ /h	Flow GPM
SSM-5-A-H-101	0.6	3.92	23.0	101
SSM-5-A-H-132	0.8	3.92	29.9	131
SSM-5-A-H-161	1.0	3.92	36.5	161
SSM-5-A-H-188	1.2	3.99	42.8	188
SSM-5-A-H-215	1.4	4.05	48.7	215
SSM-5-A-H-240	1.6	4.1	54.5	240
SSM-5-A-H-264	1.8	4.15	60.0	264
SSM-5-A-H-288	2.0	4.21	65.5	288
SSM-5-A-H-312	2.2	4.27	70.9	312
SSM-5-A-H-336	2.4	4.35	76.4	336
SSM-5-A-H-361	2.6	4.46	82.0	361
SSM-5-A-H-387	2.8	4.6	87.8	387
SSM-5-A-H-414	3.0	7.79	94.0	414
SSM-5-A-H-443	3.2	5.05	100.7	443
SSM-5-A-H-475	3.4	5.41	108.0	475
SSM-5-A-H-511	3.6	5.92	116.0	511
SSM-5-A-H-550	3.8	6.65	125.0	550
SSM-5-A-H-594	4.0	7.69	135.0	594

Note: Min. Delta P Available at Selected Flow Rate.
See Website for Specific Flow Rate Settings Calculator



Simple Set Max - ANSI 125 Flow Rate Charts

6"		6" Low Flow Rate Cartridge		
Model Number	Pre-Set	Min. Delta P	Flow m ³ /h	Flow GPM
SSM-6-A-L-113	0.6	3.05	25.6	113
SSM-6-A-L-143	0.8	3.05	32.6	143
SSM-6-A-L-173	1.0	3.05	39.2	173
SSM-6-A-L-201	1.2	3.05	45.6	201
SSM-6-A-L-228	1.4	3.05	51.8	228
SSM-6-A-L-255	1.6	3.05	58.0	255
SSM-6-A-L-282	1.8	3.05	64.1	282
SSM-6-A-L-310	2.0	3.19	70.4	310
SSM-6-A-L-338	2.2	3.39	76.8	338
SSM-6-A-L-367	2.4	3.61	83.4	367
SSM-6-A-L-398	2.6	3.86	90.3	398
SSM-6-A-L-429	2.8	4.11	97.5	429
SSM-6-A-L-462	3.0	4.35	105.0	462
SSM-6-A-L-497	3.2	4.58	112.9	497
SSM-6-A-L-533	3.4	4.77	121.1	533
SSM-6-A-L-571	3.6	4.93	129.7	571
SSM-6-A-L-610	3.8	5.03	138.7	610
SSM-6-A-L-652	4.0	5.08	148.0	652

6"		6" High Flow Rate Cartridge		
Model Number	Pre-Set	Min. Delta P	Flow m ³ /h	Flow GPM
SSM-6-A-H-141	0.6	4.79	32.0	141
SSM-6-A-H-182	0.8	4.79	41.3	182
SSM-6-A-H-220	1.0	4.79	50.0	220
SSM-6-A-H-256	1.2	4.79	58.2	256
SSM-6-A-H-291	1.4	4.79	66.0	291
SSM-6-A-H-324	1.6	4.79	73.7	324
SSM-6-A-H-358	1.8	4.79	81.3	358
SSM-6-A-H-392	2.0	4.93	89.0	392
SSM-6-A-H-427	2.2	5.16	96.9	427
SSM-6-A-H-463	2.4	5.46	105.2	4637
SSM-6-A-H-501	2.6	5.82	113.9	5017
SSM-6-A-H-542	2.8	6.23	123.1	5427
SSM-6-A-H-586	3.0	6.68	133.0	586
SSM-6-A-H-632	3.2	7.14	143.6	632
SSM-6-A-H-683	3.4	7.69	155.1	683
SSM-6-A-H-737	3.6	8.23	167.4	737
SSM-6-A-H-796	3.8	8.81	180.7	796
SSM-6-A-H-859	4.0	9.44	195.0	859

8"		8" Low Flow Rate Cartridge		
Model Number	Pre-Set	Min. Delta P	Flow m ³ /h	Flow GPM
SSM-8-A-L-418	1	1.6	95.2	418
SSM-8-A-L-435	1.2	1.7	98.8	435
SSM-8-A-L-460	1.4	1.8	104.5	460
SSM-8-A-L-485	1.6	1.9	110.2	485
SSM-8-A-L-515	1.8	2.1	117.0	515
SSM-8-A-L-545	2	2.3	123.8	545
SSM-8-A-L-575	2.2	2.5	130.6	575
SSM-8-A-L-610	2.4	2.7	138.6	610
SSM-8-A-L-640	2.6	2.9	145.4	640
SSM-8-A-L-680	2.8	3.2	154.4	680
SSM-8-A-L-720	3	3.4	163.5	720
SSM-8-A-L-760	3.2	3.7	172.6	760
SSM-8-A-L-795	3.4	3.9	180.6	795
SSM-8-A-L-835	3.6	4.2	189.7	835
SSM-8-A-L-875	3.8	4.4	198.7	875
SSM-8-A-L-925	4	4.6	209.9	925

8"		8" High Flow Rate Cartridge		
Model Number	Pre-Set	Min. Delta P	Flow m ³ /h	Flow GPM
SSM-8-A-H-572	1	4.5	130.1	572
SSM-8-A-H-598	1.2	5	135.8	598
SSM-8-A-H-630	1.4	5	143.1	630
SSM-8-A-H-664	1.6	5	150.8	664
SSM-8-A-H-702	1.8	5	159.4	702
SSM-8-A-H-739	2	6	167.9	739
SSM-8-A-H-779	2.2	6	176.9	779
SSM-8-A-H-823	2.4	7	186.9	823
SSM-8-A-H-865	2.6	7	196.5	865
SSM-8-A-H-910	2.8	8	206.7	910
SSM-8-A-H-957	3	9	217.4	957
SSM-8-A-H-1008	3.2	9	228.9	1008
SSM-8-A-H-1058	3.4	10	240.3	1058
SSM-8-A-H-1109	3.6	10	251.9	1109
SSM-8-A-H-1164	3.8	11	264.4	1164
SSM-8-A-H-1233	4	11	279.8	1233

Note: Min. Delta P Available at Selected Flow Rate.
See Website for Specific Flow Rate Settings Calculator



Simple Set Max - ANSI 125 Flow Rate Charts

10"		10" Low Flow Rate Cartridge		
Model Number	Pre-Set	Min. Delta P	Flow m ³ /h	Flow GPM
SSM-10-A-L-837	1	1.5	190.1	837
SSM-10-A-L-900	1.2	1.5	204.4	900
SSM-10-A-L-960	1.4	1.6	218.0	960
SSM-10-A-L-1020	1.6	1.7	231.7	1020
SSM-10-A-L-1075	1.8	1.9	244.2	1075
SSM-10-A-L-1135	2	2.1	257.8	1135
SSM-10-A-L-1195	2.2	2.4	271.4	1195
SSM-10-A-L-1255	2.4	2.6	285.0	1255
SSM-10-A-L-1325	2.6	2.9	300.9	1325
SSM-10-A-L-1400	2.8	3.3	318.0	1400
SSM-10-A-L-1480	3	3.6	336.1	1480
SSM-10-A-L-1570	3.2	3.9	356.6	1570
SSM-10-A-L-1680	3.4	3.4	381.6	1680
SSM-10-A-L-1795	3.6	4.5	407.7	1795
SSM-10-A-L-1930	3.8	4.8	438.4	1930
SSM-10-A-L-2091	4	5.1	474.9	2091

10"		10" High Flow Rate Cartridge		
Model Number	Pre-Set	Min. Delta P	Flow m ³ /h	Flow GPM
SSM-10-A-H-1079	1	2.18	245.1	1079
SSM-10-A-H-1118	1.2	2.3	253.9	1118
SSM-10-A-H-1178	1.4	2.5	267.6	1178
SSM-10-A-H-1246	1.6	2.8	283.0	1246
SSM-10-A-H-1330	1.8	3.1	302.1	1330
SSM-10-A-H-1420	2	3.6	322.5	1420
SSM-10-A-H-1515	2.2	4.1	344.1	1515
SSM-10-A-H-1620	2.4	4.6	367.9	1620
SSM-10-A-H-1730	2.6	5.2	392.9	1730
SSM-10-A-H-1845	2.8	5.8	419.1	1845
SSM-10-A-H-1965	3	6.4	446.3	1965
SSM-10-A-H-2090	3.2	7.1	474.7	2090
SSM-10-A-H-2220	3.4	7.8	504.2	2220
SSM-10-A-H-2355	3.6	8.6	534.9	2355
SSM-10-A-H-2490	3.8	9.3	565.5	2490
SSM-10-A-H-2642	4	10.2	599.8	2642

12"		12" Low Flow Rate Cartridge		
Model Number	Pre-Set	Min. Delta P	Flow m ³ /h	Flow GPM
SSM-12-A-L-837	1	1.5	190.1	837
SSM-12-A-L-895	1.2	1.5	203.3	895
SSM-12-A-L-955	1.4	1.6	216.9	955
SSM-12-A-L-1015	1.6	1.7	230.5	1015
SSM-12-A-L-1075	1.8	1.8	244.2	1075
SSM-12-A-L-1130	2	2.1	256.7	1130
SSM-12-A-L-1195	2.2	2.4	271.4	1195
SSM-12-A-L-1255	2.4	2.6	285.0	1255
SSM-12-A-L-1325	2.6	2.9	300.9	1325
SSM-12-A-L-1400	2.8	3.3	318.0	1400
SSM-12-A-L-1480	3	3.6	336.1	1480
SSM-12-A-L-1570	3.2	3.2	356.6	1570
SSM-12-A-L-1680	3.4	4.2	381.6	1680
SSM-12-A-L-1795	3.6	4.5	407.7	1795
SSM-12-A-L-1930	3.8	4.8	438.4	1930
SSM-12-A-L-2091	4	5.1	474.9	2091

12"		12" High Flow Rate Cartridge		
Model Number	Pre-Set	Min. Delta P	Flow m ³ /h	Flow GPM
SSM-12-A-H-1079	1	2.2	245.1	1079
SSM-12-A-H-1118	1.2	2.3	253.9	1118
SSM-12-A-H-1178	1.4	2.5	267.6	1178
SSM-12-A-H-1248	1.6	2.8	283.5	1248
SSM-12-A-H-1330	1.8	3.1	302.1	1330
SSM-12-A-H-1418	2	3.6	322.1	1418
SSM-12-A-H-1515	2.2	4.1	344.1	1515
SSM-12-A-H-1618	2.4	4.6	367.5	1618
SSM-12-A-H-1730	2.6	5.2	392.9	1730
SSM-12-A-H-1847	2.8	5.8	419.5	1847
SSM-12-A-H-1969	3	6.5	447.2	1969
SSM-12-A-H-2090	3.2	7.1	474.7	2090
SSM-12-A-H-2225	3.4	7.9	505.4	2225
SSM-12-A-H-2350	3.6	8.6	533.7	2350
SSM-12-A-H-2490	3.8	9.3	565.5	2490
SSM-12-A-H-2642	4	10.2	599.8	2642

Note: Min. Delta P Available at Selected Flow Rate.
See Website for Specific Flow Rate Settings Calculator



Simple Set Max - ANSI 250 Flow Rate Charts

2-1/2"		2-1/2" Low Flow Rate Cartridge		
Model Number	Pre-Set	Min. Delta P	Flow m ³ /h	Flow GPM
SSM-250-A250-L-19	0.6	2.18	4.4	19
SSM-250-A250-L-24	0.8	2.18	5.6	24
SSM-250-A250-L-29	1.0	2.18	6.6	29
SSM-250-A250-L-34	1.2	2.31	7.7	34
SSM-250-A250-L-38	1.4	2.41	8.6	38
SSM-250-A250-L-42	1.6	2.49	9.6	42
SSM-250-A250-L-46	1.8	2.55	10.5	46
SSM-250-A250-L-51	2.0	2.61	11.5	51
SSM-250-A250-L-55	2.2	2.66	12.5	55
SSM-250-A250-L-60	2.4	2.7	13.5	60
SSM-250-A250-L-65	2.6	2.76	14.7	65
SSM-250-A250-L-70	2.8	2.82	15.8	70
SSM-250-A250-L-75	3.0	2.9	17.1	75
SSM-250-A250-L-81	3.2	3	18.5	81
SSM-250-A250-L-88	3.4	3.11	19.9	88
SSM-250-A250-L-95	3.6	3.26	21.5	95
SSM-250-A250-L-102	3.8	3.42	23.2	102
SSM-250-A250-L-110	4.0	3.59	25.0	110

2-1/2"		2-1/2" High Flow Rate Cartridge		
Model Number	Pre-Set	Min. Delta P	Flow m ³ /h	Flow GPM
SSM-250-A250-H-26	0.6	4.35	6.0	26
SSM-250-A250-H-33	0.8	4.35	7.6	33
SSM-250-A250-H-40	1.0	4.35	9.1	40
SSM-250-A250-H-46	1.2	4.51	10.5	46
SSM-250-A250-H-53	1.4	4.6	11.9	53
SSM-250-A250-H-59	1.6	4.64	13.3	59
SSM-250-A250-H-65	1.8	4.65	14.7	65
SSM-250-A250-H-71	2.0	4.64	16.0	71
SSM-250-A250-H-77	2.2	4.64	17.5	77
SSM-250-A250-H-84	2.4	4.67	19.0	84
SSM-250-A250-H-91	2.6	4.74	20.6	91
SSM-250-A250-H-98	2.8	4.87	22.3	98
SSM-250-A250-H-106	3.0	5.09	24.1	106
SSM-250-A250-H-114	3.2	5.4	26.0	114
SSM-250-A250-H-123	3.4	5.81	28.0	123
SSM-250-A250-H-133	3.6	6.36	30.2	133
SSM-250-A250-H-143	3.8	7.06	32.5	143
SSM-250-A250-H-154	4.0	8.01	35.0	154

3"		3" Low Flow Rate Cartridge		
Model Number	Pre-Set	Min. Delta P	Flow m ³ /h	Flow GPM
SSM-3-A250-L-26	0.6	2.32	5.3	26
SSM-3-A250-L-30	0.8	2.32	6.9	30
SSM-3-A250-L-36	1.0	2.33	8.3	36
SSM-3-A250-L-42	1.2	2.41	9.6	42
SSM-3-A250-L-48	1.4	2.47	10.9	48
SSM-3-A250-L-54	1.6	2.52	12.2	54
SSM-3-A250-L-59	1.8	2.57	13.5	59
SSM-3-A250-L-65	2.0	2.61	14.8	65
SSM-3-A250-L-71	2.2	2.65	16.2	71
SSM-3-A250-L-77	2.4	2.7	17.6	77
SSM-3-A250-L-84	2.6	2.75	19.1	84
SSM-3-A250-L-91	2.8	2.82	20.7	91
SSM-3-A250-L-99	3.0	2.9	22.4	99
SSM-3-A250-L-107	3.2	3	24.3	107
SSM-3-A250-L-116	3.4	3.13	26.4	116
SSM-3-A250-L-126	3.6	3.28	28.7	126
SSM-3-A250-L-138	3.8	3.44	31.2	138
SSM-3-A250-L-150	4.0	3.61	34.0	150

3"		3" High Flow Rate Cartridge		
Model Number	Pre-Set	Min. Delta P	Flow m ³ /h	Flow GPM
SSM-3-A250-H-31	0.6	3.34	7.0	31
SSM-3-A250-H-40	0.8	3.34	9.0	40
SSM-3-A250-H-48	1.0	3.34	11.0	48
SSM-3-A250-H-56	1.2	3.43	12.8	56
SSM-3-A250-H-64	1.4	3.49	14.5	64
SSM-3-A250-H-71	1.6	3.53	16.2	71
SSM-3-A250-H-79	1.8	3.57	18.0	79
SSM-3-A250-H-86	2.0	3.61	19.6	86
SSM-3-A250-H-94	2.2	3.68	21.4	94
SSM-3-A250-H-102	2.4	3.77	23.2	102
SSM-3-A250-H-111	2.6	3.91	25.1	111
SSM-3-A250-H-119	2.8	4.11	27.1	119
SSM-3-A250-H-129	3.0	4.39	29.3	129
SSM-3-A250-H-139	3.2	4.75	31.6	139
SSM-3-A250-H-150	3.4	5.19	34.1	150
SSM-3-A250-H-162	3.6	5.73	36.8	162
SSM-3-A250-H-175	3.8	6.39	39.8	175
SSM-3-A250-H-189	4.0	7.19	43.0	189

Note: Min. Delta P Available at Selected Flow Rate.
See Website for Specific Flow Rate Settings Calculator



Simple Set Max - ANSI 250 Flow Rate Charts

4"		4" Low Flow Rate Cartridge		
Model Number	Pre-Set	Min. Delta P	Flow m ³ /h	Flow GPM
SSM-4-A250-L-53	0.6	2.75	12.1	53
SSM-4-A250-L-67	0.8	2.83	15.3	67
SSM-4-A250-L-80	1.0	2.9	18.1	80
SSM-4-A250-L-91	1.2	2.96	20.8	91
SSM-4-A250-L-102	1.4	3.02	23.2	102
SSM-4-A250-L-112	1.6	3.08	25.5	112
SSM-4-A250-L-122	1.8	3.13	27.8	122
SSM-4-A250-L-132	2.0	3.19	30.0	132
SSM-4-A250-L-143	2.2	3.25	32.4	143
SSM-4-A250-L-154	2.4	3.32	34.9	154
SSM-4-A250-L-166	2.6	3.4	37.6	166
SSM-4-A250-L-179	2.8	3.5	40.6	179
SSM-4-A250-L-194	3.0	3.63	44.0	194
SSM-4-A250-L-210	3.2	3.78	47.7	210
SSM-4-A250-L-229	3.4	3.98	51.9	229
SSM-4-A250-L-249	3.6	4.25	56.7	249
SSM-4-A250-L-273	3.8	4.6	62.0	273
SSM-4-A250-L-299	4.0	5.08	68.0	299

4"		4" High Flow Rate Cartridge		
Model Number	Pre-Set	Min. Delta P	Flow m ³ /h	Flow GPM
SSM-4-A250-H-65	0.6	4.14	14.8	65
SSM-4-A250-H-83	0.8	4.24	18.9	83
SSM-4-A250-H-99	1.0	4.35	22.6	99.
SSM-4-A250-H-114	1.2	4.48	26.0	114
SSM-4-A250-H-128	1.4	4.61	29.1	128
SSM-4-A250-H-141	1.6	4.75	32.1	141
SSM-4-A250-H-154	1.8	4.91	35.1	154
SSM-4-A250-H-168	2.0	5.08	38.1	168
SSM-4-A250-H-181	2.2	5.27	41.2	181
SSM-4-A250-H-196	2.4	5.5	44.5	196
SSM-4-A250-H-212	2.6	5.78	48.2	212
SSM-4-A250-H-230	2.8	6.11	52.2	230
SSM-4-A250-H-250	3.0	6.52	56.7	250
SSM-4-A250-H-272	3.2	7.05	61.9	272
SSM-4-A250-H-298	3.4	7.7	67.7	298
SSM-4-A250-H-327	3.6	8.51	74.2	327
SSM-4-A250-H-360	3.8	9.56	81.7	360
SSM-4-A250-H-396	4.0	10.87	90.0	396

5"		5" Low Flow Rate Cartridge		
Model Number	Pre-Set	Min. Delta P	Flow m ³ /h	Flow GPM
SSM-5-A250-L-81	0.6	2.32	18.5	81
SSM-5-A250-L-104	0.8	2.32	23.6	104
SSM-5-A250-L-125	1.0	2.32	28.5	125
SSM-5-A250-L-147	1.2	2.39	33.3	147
SSM-5-A250-L-167	1.4	2.46	38.0	167
SSM-5-A250-L-188	1.6	2.51	42.6	188
SSM-5-A250-L-207	1.8	2.56	47.1	207
SSM-5-A250-L-227	2.0	2.61	51.5	227
SSM-5-A250-L-246	2.2	2.67	55.9	246
SSM-5-A250-L-266	2.4	2.73	60.4	266
SSM-5-A250-L-286	2.6	2.81	65.0	286
SSM-5-A250-L-308	2.8	2.91	69.8	308
SSM-5-A250-L-330	3.0	3.05	75.0	330
SSM-5-A250-L-355	3.2	3.23	80.6	355
SSM-5-A250-L-382	3.4	3.48	86.7	382
SSM-5-A250-L-412	3.6	3.83	93.6	412
SSM-5-A250-L-446	3.8	4.34	101.3	446
SSM-5-A250-L-484	4.0	5.08	110.0	484

5"		5" High Flow Rate Cartridge		
Model Number	Pre-Set	Min. Delta P	Flow m ³ /h	Flow GPM
SSM-5-A250-H-101	0.6	3.92	23.0	101
SSM-5-A250-H-132	0.8	3.92	29.9	132
SSM-5-A250-H-161	1.0	3.92	36.5	161
SSM-5-A250-H-188	1.2	3.99	42.8	188
SSM-5-A250-H-215	1.4	4.05	48.7	215
SSM-5-A250-H-240	1.6	4.1	54.5	240
SSM-5-A250-H-264	1.8	4.15	60.0	264
SSM-5-A250-H-288	2.0	4.21	65.5	288
SSM-5-A250-H-312	2.2	4.27	70.9	312
SSM-5-A250-H-336	2.4	4.35	76.4	336
SSM-5-A250-H-361	2.6	4.46	82.0	361
SSM-5-A250-H-387	2.8	4.6	87.8	387
SSM-5-A250-H-414	3.0	7.79	94.0	414
SSM-5-A250-H-443	3.2	5.05	100.7	443
SSM-5-A250-H-475	3.4	5.41	108.0	475
SSM-5-A250-H-511	3.6	5.92	116.0	511
SSM-5-A250-H-550	3.8	6.65	125.0	550
SSM-5-A250-H-594	4.0	7.69	135.0	594

Note: Min. Delta P Available at Selected Flow Rate.
See Website for Specific Flow Rate Settings Calculator



Simple Set Max - ANSI 250 Flow Rate Charts

6"		6" Low Flow Rate Cartridge		
Model Number	Pre-Set	Min. Delta P	Flow m ³ /h	Flow GPM
SSM-6-A250-L-113	0.6	3.05	25.6	113
SSM-6-A250-L-143	0.8	3.05	32.6	143
SSM-6-A250-L-173	1.0	3.05	39.2	173
SSM-6-A250-L-201	1.2	3.05	45.6	201
SSM-6-A250-L-228	1.4	3.05	51.8	228
SSM-6-A250-L-255	1.6	3.05	58.0	255
SSM-6-A250-L-282	1.8	3.05	64.1	282
SSM-6-A250-L-310	2.0	3.19	70.4	310
SSM-6-A250-L-338	2.2	3.39	76.8	338
SSM-6-A250-L-367	2.4	3.61	83.4	367
SSM-6-A250-L-398	2.6	3.86	90.3	398
SSM-6-A250-L-429	2.8	4.11	97.5	429
SSM-6-A250-L-462	3.0	4.35	105.0	462
SSM-6-A250-L-497	3.2	4.58	112.9	497
SSM-6-A250-L-533	3.4	4.77	121.1	533
SSM-6-A250-L-571	3.6	4.93	129.7	571
SSM-6-A250-L-610	3.8	5.03	138.7	610
SSM-6-A250-L-652	4.0	5.08	148.0	652

6"		6" High Flow Rate Cartridge		
Model Number	Pre-Set	Min. Delta P	Flow m ³ /h	Flow GPM
SSM-6-A250-H-141	0.6	4.79	32.0	141
SSM-6-A250-H-182	0.8	4.79	41.3	182
SSM-6-A250-H-220	1.0	4.79	50.0	220
SSM-6-A250-H-256	1.2	4.79	58.2	256
SSM-6-A250-H-291	1.4	4.79	66.0	291
SSM-6-A250-H-324	1.6	4.79	73.7	324
SSM-6-A250-H-358	1.8	4.79	81.3	358
SSM-6-A250-H-392	2.0	4.93	89.0	392
SSM-6-A250-H-427	2.2	5.16	96.9	427
SSM-6-A250-H-463	2.4	5.46	105.2	463
SSM-6-A250-H-501	2.6	5.82	113.9	501
SSM-6-A250-H-542	2.8	6.23	123.1	542
SSM-6-A250-H-586	3.0	6.68	133.0	586
SSM-6-A250-H-632	3.2	7.14	143.6	632
SSM-6-A250-H-683	3.4	7.69	155.1	683
SSM-6-A250-H-737	3.6	8.23	167.4	737
SSM-6-A250-H-796	3.8	8.81	180.7	796
SSM-6-A250-H-859	4.0	9.44	195.0	859

8"		8" Low Flow Rate Cartridge		
Model Number	Pre-Set	Min. Delta P	Flow m ³ /h	Flow GPM
SSM-8-A250-L-418	1	1.6	95.2	418
SSM-8-A250-L-435	1.2	1.7	98.8	435
SSM-8-A250-L-460	1.4	1.8	104.5	460
SSM-8-A250-L-485	1.6	1.9	110.2	485
SSM-8-A250-L-515	1.8	2.1	117.0	515
SSM-8-A250-L-545	2	2.3	123.8	545
SSM-8-A250-L-575	2.2	2.5	130.6	575
SSM-8-A250-L-610	2.4	2.7	138.6	610
SSM-8-A250-L-640	2.6	2.9	145.4	640
SSM-8-A250-L-680	2.8	3.2	154.4	680
SSM-8-A250-L-720	3	3.4	163.5	720
SSM-8-A250-L-760	3.2	3.7	172.6	760
SSM-8-A250-L-795	3.4	3.9	180.6	795
SSM-8-A250-L-835	3.6	4.2	189.7	835
SSM-8-A250-L-875	3.8	4.4	198.7	875
SSM-8-A250-L-925	4	4.6	209.9	925

8"		8" High Flow Rate Cartridge		
Model Number	Pre-Set	Min. Delta P	Flow m ³ /h	Flow GPM
SSM-8-A250-H-572	1	4.5	130.1	572
SSM-8-A250-H-598	1.2	5	135.8	598
SSM-8-A250-H-630	1.4	5	143.1	630
SSM-8-A250-H-664	1.6	5	150.8	664
SSM-8-A250-H-702	1.8	5	159.4	702
SSM-8-A250-H-739	2	6	167.9	739
SSM-8-A250-H-779	2.2	6	176.9	779
SSM-8-A250-H-823	2.4	7	186.9	823
SSM-8-A250-H-865	2.6	7	196.5	865
SSM-8-A250-H-910	2.8	8	206.7	910
SSM-8-A250-H-957	3	9	217.4	957
SSM-8-A250-H-1008	3.2	9	228.9	1008
SSM-8-A250-H-1058	3.4	10	240.3	1058
SSM-8-A250-H-1109	3.6	10	251.9	1109
SSM-8-A250-H-1164	3.8	11	264.4	1164
SSM-8-A250-H-1233	4	11	279.8	1233

Note: Min. Delta P Available at Selected Flow Rate.
See Website for Specific Flow Rate Settings Calculator



Simple Set Max - ANSI 250 Flow Rate Charts

10"		10" Low Flow Rate Cartridge		
Model Number	Pre-Set	Min. Delta P	Flow m ³ /h	Flow GPM
SSM-10-A250-L-837	1	1.5	190.1	837
SSM-10-A250-L-900	1.2	1.5	204.4	900
SSM-10-A250-L-960	1.4	1.6	218.0	960
SSM-10-A250-L-1020	1.6	1.7	231.7	1020
SSM-10-A250-L-1075	1.8	1.9	244.2	1075
SSM-10-A250-L-1135	2	2.1	257.8	1135
SSM-10-A250-L-1195	2.2	2.4	271.4	1195
SSM-10-A250-L-1255	2.4	2.6	285.0	1255
SSM-10-A250-L-1325	2.6	2.9	300.9	1325
SSM-10-A250-L-1400	2.8	3.3	318.0	1400
SSM-10-A250-L-1480	3	3.6	336.1	1480
SSM-10-A250-L-1570	3.2	3.9	356.6	1570
SSM-10-A250-L-1680	3.4	3.4	381.6	1680
SSM-10-A250-L-1795	3.6	4.5	407.7	1795
SSM-10-A250-L-1930	3.8	4.8	438.4	1930
SSM-10-A250-L-2091	4	5.1	474.9	2091

10"		10" High Flow Rate Cartridge		
Model Number	Pre-Set	Min. Delta P	Flow m ³ /h	Flow GPM
SSM-10-A250-H-1079	1	2.18	245.1	1079
SSM-10-A250-H-1118	1.2	2.3	253.9	1118
SSM-10-A250-H-1178	1.4	2.5	267.6	1178
SSM-10-A250-H-1246	1.6	2.8	283.0	1246
SSM-10-A250-H-1330	1.8	3.1	302.1	1330
SSM-10-A250-H-1420	2	3.6	322.5	1420
SSM-10-A250-H-1515	2.2	4.1	344.1	1515
SSM-10-A250-H-1620	2.4	4.6	367.9	1620
SSM-10-A250-H-1730	2.6	5.2	392.9	1730
SSM-10-A250-H-1845	2.8	5.8	419.1	1845
SSM-10-A250-H-1965	3	6.4	446.3	1965
SSM-10-A250-H-2090	3.2	7.1	474.7	2090
SSM-10-A250-H-2220	3.4	7.8	504.2	2220
SSM-10-A250-H-2355	3.6	8.6	534.9	2355
SSM-10-A250-H-2490	3.8	9.3	565.5	2490
SSM-10-A250-H-2642	4	10.2	599.8	2642

12"		12" Low Flow Rate Cartridge		
Model Number	Pre-Set	Min. Delta P	Flow m ³ /h	Flow GPM
SSM-12-A250-L-837	1	1.5	190.1	837
SSM-12-A250-L-895	1.2	1.5	203.3	895
SSM-12-A250-L-955	1.4	1.6	216.9	955
SSM-12-A250-L-1015	1.6	1.7	230.5	1015
SSM-12-A250-L-1075	1.8	1.8	244.2	1075
SSM-12-A250-L-1130	2	2.1	256.7	1130
SSM-12-A250-L-1195	2.2	2.4	271.4	1195
SSM-12-A250-L-1255	2.4	2.6	285.0	1255
SSM-12-A250-L-1325	2.6	2.9	300.9	1325
SSM-12-A250-L-1400	2.8	3.3	318.0	1400
SSM-12-A250-L-1480	3	3.6	336.1	1480
SSM-12-A250-L-1570	3.2	3.2	356.6	1570
SSM-12-A250-L-1680	3.4	4.2	381.6	1680
SSM-12-A250-L-1795	3.6	4.5	407.7	1795
SSM-12-A250-L-1930	3.8	4.8	438.4	1930
SSM-12-A250-L-2091	4	5.1	474.9	2091

12"		12" High Flow Rate Cartridge		
Model Number	Pre-Set	Min. Delta P	Flow m ³ /h	Flow GPM
SSM-12-A250-H-1079	1	2.2	245.1	1079
SSM-12-A250-H-1118	1.2	2.3	253.9	1118
SSM-12-A250-H-1178	1.4	2.5	267.6	1178
SSM-12-A250-H-1248	1.6	2.8	283.5	1248
SSM-12-A250-H-1330	1.8	3.1	302.1	1330
SSM-12-A250-H-1418	2	3.6	322.1	1418
SSM-12-A250-H-1515	2.2	4.1	344.1	1515
SSM-12-A250-H-1618	2.4	4.6	367.5	1618
SSM-12-A250-H-1730	2.6	5.2	392.9	1730
SSM-12-A250-H-1847	2.8	5.8	419.5	1847
SSM-12-A250-H-1969	3	6.5	447.2	1969
SSM-12-A250-H-2090	3.2	7.1	474.7	2090
SSM-12-A250-H-2225	3.4	7.9	505.4	2225
SSM-12-A250-H-2350	3.6	8.6	533.7	2350
SSM-12-A250-H-2490	3.8	9.3	565.5	2490
SSM-12-A250-H-2642	4	10.2	599.8	2642

Note: Min. Delta P Available at Selected Flow Rate.
See Website for Specific Flow Rate Settings Calculator



Simple Set Max - ANSI 125 Dimensions - 2-1/2" - 12"

Simple Set Max ANSI 125 Dimensions with GA(S) Actuators — 2-1/2" - 12"															
ANSI 125 Model #	Connection		Flow Range	Please Reference the Illustration											
	in.	mm		L		H		H1		D		W		Weight	
x = Flow in GPM	in.	mm	GPM	in.	mm	in.	mm	in.	mm	in.	mm	in.	mm	lbs	kg
SSM-250-A-L-x	2.5	65	19 - 110	10.87	276	3.51	89	19.12	486	7.01	178	6.41	163	41	19
SSM-250-A-H-x	2.5	65	26 - 154	10.87	276	3.51	89	19.12	486	7.01	178	6.41	163	41	19
SSM-3-A-L-x	3.0	80	26 - 150	11.73	298	3.75	95	19.98	507	7.52	191	7.96	202	61	28
SSM-3-A-H-x	3.0	80	31 - 189	11.73	298	3.75	95	19.98	507	7.52	191	7.96	202	61	28
SSM-4-A-L-x	4.0	100	53 - 299	13.86	352	4.51	115	24.52	623	9.02	229	10.53	267	123	56
SSM-4-A-H-x	4.0	100	65 - 396	13.86	352	4.51	115	24.52	623	9.02	229	10.53	267	123	56
SSM-5-A-L-x	5.0	125	81 - 484	15.75	400	5.00	127	25.58	650	10.00	254	11.90	302	171	78
SSM-5-A-H-x	5.0	125	101 - 594	15.75	400	5.00	127	25.58	650	10.00	254	11.90	302	171	78
SSM-6-A-L-x	6.0	150	113 - 652	17.76	451	5.49	139	27.26	692	10.98	279	14.00	356	241	109
SSM-6-A-H-x	6.0	150	141 - 859	17.76	451	5.49	139	27.26	692	10.98	279	14.00	356	241	109
SSM-8-A-L-x	8.0	200	419 - 925	23.62	600	7.48	190	27.38	695	14.96	380	18.58	472	386	175
SSM-8-A-H-x	8.0	200	572 - 1233	23.62	600	7.48	190	27.38	695	14.96	380	18.58	472	386	175
SSM-10-A-L-x	10.0	250	837 - 2091	28.74	730	8.74	222	33.44	849	17.48	444	21.69	551	677	307
SSM-10-A-H-x	10.0	250	1079 - 2642	28.74	730	8.74	222	33.44	849	17.48	444	21.69	551	677	307
SSM-12-A-L-x	12.0	300	837 - 2091	33.46	850	10.24	260	33.44	849	20.47	520	28.39	721	1036	470
SSM-12-A-H-x	12.0	300	1079 - 2642	33.46	850	10.24	260	33.44	849	20.47	520	28.39	721	1036	470

GA Series (Non-Spring Return) Actuators only

Weights shown are for valve/actuator assemblies
Add 3.2 lbs. (1.5 kg) for spring return GA(S) actuator

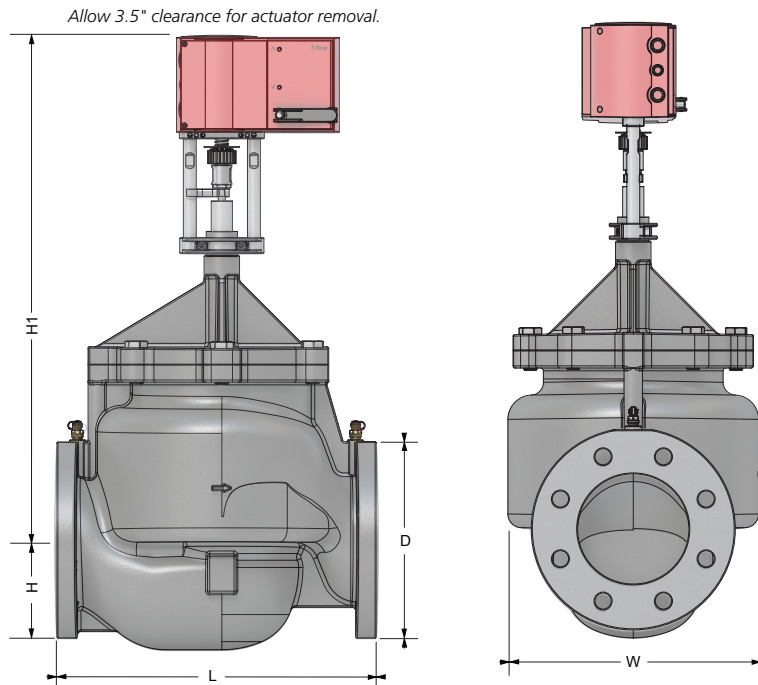



Simple Set Max - ANSI 250 Dimensions - 2-1/2" - 12"

Simple Set Max Dimensions — 2-1/2" - 12" — ANSI 250 with GA(S) Series Actuators															
ANSI 250 Model Number	Valve Size		Flow Range	Please Reference the Illustration											
				L		W		H		H1		D		Weight	
x = Flow in GPM	in.	mm	GPM	in.	mm	in.	mm	in.	mm	in.	mm	in.	mm	lb.	kg.
SSM-250-A250-L-x	2.5	65	19 - 110	11.50	292	7.50	191	3.70	95	19.20	487	7.50	189	64.0	29
SSM-250-A250-H-x	2.5	65	26 - 154	11.50	292	7.50	191	3.70	95	19.20	487	7.50	189	64.0	29
SSM-3-A250-L-x	3	80	26 - 150	12.50	318	8.30	212	4.10	104	20.00	509	8.20	209	88.2	40
SSM-3-A250-H-x	3	80	31 - 189	12.50	318	8.30	212	4.10	104	20.00	509	8.20	209	88.2	40
SSM-4-A250-L-x	4	100	53 - 299	14.50	368	10.80	274	5.00	127	25.30	643	10.00	253	167.6	76
SSM-4-A250-H-x	4	100	65 - 396	14.50	368	10.80	274	5.00	127	25.30	643	10.00	253	167.6	76
SSM-5-A250-L-x	5	125	81 - 484	16.60	422	12.30	312	5.50	139	26.30	668	10.90	277	231.5	105
SSM-5-A250-H-x	5	125	101 - 594	16.60	422	12.30	312	5.50	139	26.30	668	10.90	277	231.5	105
SSM-6-A250-L-x	6	150	113 - 652	18.60	473	14.40	365	6.30	159	28.10	713	12.50	317	319.7	145
SSM-6-A250-H-x	6	150	141 - 859	18.60	473	14.40	365	6.30	159	28.10	713	12.50	317	319.7	145
SSM-8-A250-L-x	8	200	419 - 925	23.60	600	18.60	472	7.50	190	28.20	715	15.00	380	392.4	178
SSM-8-A250-H-x	8	200	572 - 1233	23.60	600	18.60	472	7.50	190	28.20	715	15.00	380	392.4	178
SSM-10-A250-L-x	10	250	837 - 2091	28.80	730	21.70	551	8.70	222	34.20	870	17.50	444	685.6	311
SSM-10-A250-H-x	10	250	1079 - 2642	28.80	730	21.70	551	8.70	222	34.20	870	17.50	444	685.6	311
SSM-12-A250-L-x	12	300	837 - 2091	33.50	850	28.40	721	10.20	260	34.20	869	20.50	520	1047.2	475
SSM-12-A250-H-x	12	300	1079 - 2642	33.50	850	28.40	721	10.20	260	34.20	869	20.50	520	1047.2	475

GA Series (Non-Spring Return) Actuators only

Weights shown are for valve/actuator assemblies
Add 3.2 lbs. (1.5 kg) for spring return GA(S) actuator

